



Rene Swiss Corp.

Rene Swiss Corporation



Product Catalog

Solid Carbide Drills

Phone: 203.879.4822
www.reneswiss.com

Fax: 203.879.0732
rachel@reneswiss.com



Rene Swiss Corp.

NC - Center Drills 90°

Type 1106 R

R = right hand cut
* = logarithmically ground

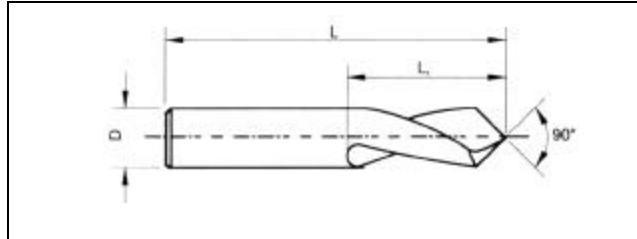

Other executions or dimensions and tolerances on request

D1 h6	L1	L
3.00	7.00	38
4.00	8.00	50
6.00	10.00	57
* 8.00	16.00	63
* 10.00	19.00	72
* 12.00	22.00	83
* 16.00	26.00	92
* 20.00	32.00	104

Type 1106 L

L = left hand cut

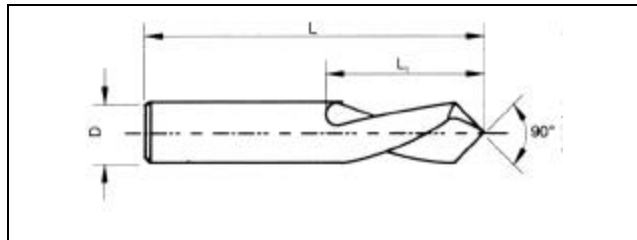

Other executions or dimensions and tolerances on request

D1 h6	L1	L
4.00	8.00	50
5.00	10.00	50
6.00	16.00	50



Rene Swiss Corp.

NC - Center Drills 120°

Type 1107 R

R = right hand cut
* = logarithmically ground

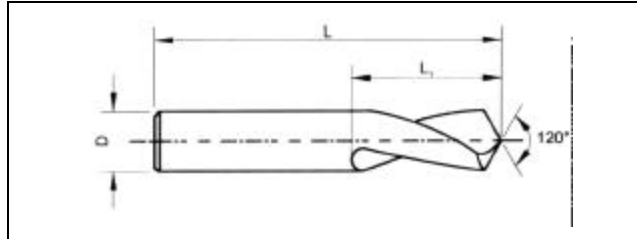

Other executions
or dimensions and
tolerances on
request

D1 h6	L1	L
3.00	7.00	38
4.00	8.00	50
6.00	10.00	57
* 8.00	16.00	63
* 10.00	19.00	72
* 12.00	22.00	83
* 16.00	26.00	92
* 20.00	35.00	100



Single Flute Gun Drills

Type 1111 R & L

R = right hand cut
L = left hand cut

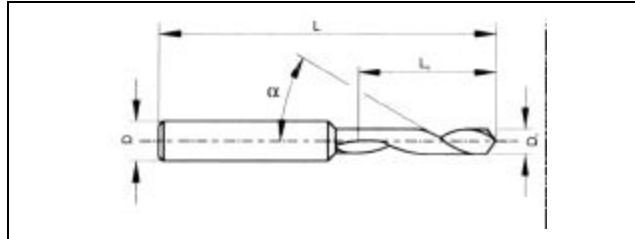

Other executions
or dimensions and
tolerances on
request

D1 h6	L1	D h6	L
0.08 - 0.14	0.70	1.00	30
0.15 - 0.19	1.00	1.00	30
0.20 - 0.29	1.00	1.00	30
0.30 - 0.39	1.50	1.00	30
0.40 - 0.49	2.00	1.00	30
0.50 - 0.59	3.00	1.00	30
0.60 - 0.64	3.50	1.00	30
0.65 - 0.69	4.00	1.00	30
0.70 - 0.79	4.50	1.00	30
0.80 - 0.89	5.00	1.50	30
0.90 - 0.99	5.50	1.50	30
1.00 - 1.49	9.00	1.50	30
1.50 - 1.99	10.00	2.00	38
2.00 - 2.49	12.00	2.50	43
2.50 - 2.99	15.00	3.00	46
3.00 - 3.49	18.00	3.50	50
3.50 - 3.99	18.00	4.00	50
4.00 - 4.49	20.00	4.50	50
4.50 - 4.99	22.00	5.00	50
5.00 - 5.49	25.00	5.50	50
5.50 - 5.99	25.00	6.00	50

For accurate drilling and when an excellent
surface finish is required (rotating tools)

Single Flute Stepped Gun Drills

Type 1511 R & L

Per request



Pointed Drills

Type 1112 R & L

R = right hand cut
L = left hand cut

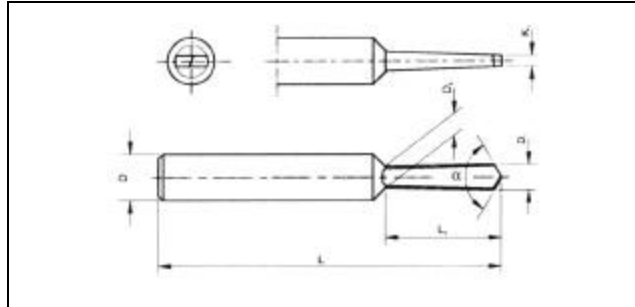

Other executions
or dimensions and
tolerances on
request

D1 h6	L1	D h6	L
0.10 - 0.14	0.70	1.00	30
0.15 - 0.19	1.00	1.00	30
0.20 - 0.29	1.00	1.00	30
0.30 - 0.39	1.50	1.00	30
0.40 - 0.49	2.00	1.00	30
0.50 - 0.59	3.00	1.00	30
0.60 - 0.64	3.50	1.00	30
0.65 - 0.69	4.00	1.00	30
0.70 - 0.79	4.50	1.00	30
0.80 - 0.89	5.00	1.50	30
0.90 - 0.99	5.50	1.50	30
1.00 - 1.49	9.00	1.50	30
1.50 - 1.99	10.00	2.00	38
2.00 - 2.49	12.00	2.50	43
2.50 - 2.99	15.00	3.00	46
3.00 - 3.49	18.00	3.50	50
3.50 - 3.99	18.00	4.00	50
4.00 - 4.49	20.00	4.50	50
4.50 - 4.99	22.00	5.00	50
5.00 - 5.49	25.00	5.50	50
5.50 - 5.99	25.00	6.00	50

When ordering, please specify
the material to be machined which
will determine the geometry as well
as D1, L1, D, L and the direction
of cut (R or L)

Stepped Pointed Drills

Type 1512

Per request



Half-moon Bits

Type 1114 R & L

R = right hand cut
L = left hand cut

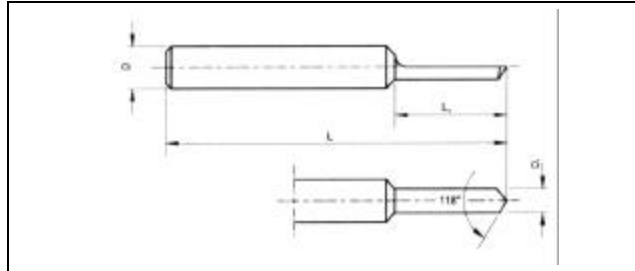

Other executions
or dimensions and
tolerances on
request

D1 h6	L1	D h6	L
0.08 - 0.14	0.70	1.00	30
0.15 - 0.19	1.00	1.00	30
0.20 - 0.29	1.00	1.00	30
0.30 - 0.39	1.50	1.00	30
0.40 - 0.49	2.00	1.00	30
0.50 - 0.59	3.00	1.00	30
0.60 - 0.64	3.50	1.00	30
0.65 - 0.69	4.00	1.00	30
0.70 - 0.79	4.50	1.00	30
0.80 - 0.89	5.00	1.50	30
0.90 - 0.99	5.50	1.50	30
1.00 - 1.49	9.00	1.50	30
1.50 - 1.99	10.00	2.00	38
2.00 - 2.49	12.00	2.50	43
2.50 - 2.99	15.00	3.00	46
3.00 - 3.49	18.00	3.50	50
3.50 - 3.99	18.00	4.00	50
4.00 - 4.49	20.00	4.50	50
4.50 - 4.99	22.00	5.00	50
5.00 - 5.49	25.00	5.50	50
5.50 - 5.99	25.00	6.00	50

When ordering, please specify
the material to be machined which
will determine the geometry as well
as D1, L1, D, L and the direction
of cut (R or L)

Half-moon Stepped Gun Drills

Type 1514 R & L

Per request



Drills Eureka

Type 1118 R & L

R = right hand cut
L = left hand cut

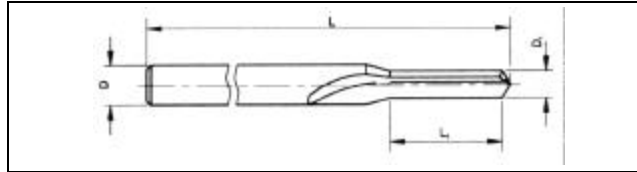

Other executions
or dimensions and
tolerances on
request

D1 h6	L1	D h6	L
0.50 - 0.53	4.00	1.00	30
0.54 - 0.60	4.50	1.00	30
0.61 - 0.67	5.00	1.00	30
0.68 - 0.75	5.60	1.00	30
0.76 - 0.79	6.30	1.00	30
0.80 - 0.85	6.30	1.50	30
0.86 - 0.95	7.10	1.50	30
0.96 - 0.99	8.00	1.50	30
1.00 - 1.18	9.00	1.50	30
1.19 - 1.32	10.00	1.50	30
1.33 - 1.49	11.20	1.50	30
1.50	11.20	2.00	38
1.51 - 1.99	12.00	2.00	38
2.00 - 2.45	12.00	2.50	43
2.50	12.00	3.00	50
2.60 - 2.95	12.00	4.00	50
3.00 - 3.75	14.00	6.00	62
3.80 - 4.75	17.00	6.00	66
4.80 - 5.50	20.00	6.00	66
5.60 - 6.00	21.00	6.00	66

When ordering, please specify
the material to be machined which
will determine the geometry as well
as D1, L1, D, L and the direction
of cut (R or L)

Essentially used in machining
of brass (fixed tools)

Stepped Drills Eureka

Type 1518 R & L

Per request



Twist Drills Long Execution

Type 1126 R

R = right hand cut

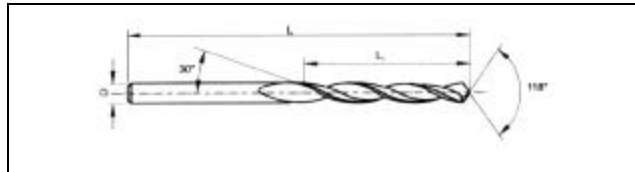

Other executions or dimensions and tolerances as well as TiN or TiAlN coating on request

D1 h6	L1	L	D1 h6	L1	L
1.00	12.00	34	6.00	57.00	93
1.10	14.00	36	* 6.10 - 6.40	63.00	101
1.20	13.00	38	6.50	63.00	101
1.30	13.00	38	* 6.60 - 6.70	63.00	101
1.40	18.00	40	* 6.80 - 7.00	69.00	109
1.50	18.00	40	7.50	69.00	109
1.60	20.00	43	8.00	75.00	117
1.70	20.00	43	8.50	75.00	117
1.80	22.00	46	9.00	81.00	125
1.90	22.00	46	9.50	81.00	125
2.00	24.00	49	10.00	87.00	133
2.10	24.00	49	10.20	87.00	133
* 2.20 - 2.30	27.00	53	10.50	87.00	133
* 2.40 - 2.50	30.00	57	11.00	94.00	142
* 2.60 - 3.00	30.00	57	11.50	94.00	142
* 3.10 - 3.30	36.00	65	12.00	101.00	151
3.40	39.00	70	12.50	101.00	151
3.50	39.00	70	13.00	101.00	151
* 3.60 - 3.70	39.00	70	13.50	108.00	160
* 3.80 - 3.90	43.00	75	14.00	108.00	160
4.00	43.00	75			
* 4.10 - 4.20	43.00	75			
* 4.30 - 4.40	47.00	80			
4.50	47.00	80			
* 4.60 - 4.70	47.00	80			
* 4.80 - 4.90	52.00	86			
5.00	52.00	86			
* 5.10 - 5.30	52.00	86			
* 5.40 - 5.50	57.00	93			
* 5.60 - 5.70	57.00	93			
* 5.80 - 5.90	57.00	93			

* available per 0.10mm



Drills With Progressive Helix

Type 1128 L

L = left hand cut

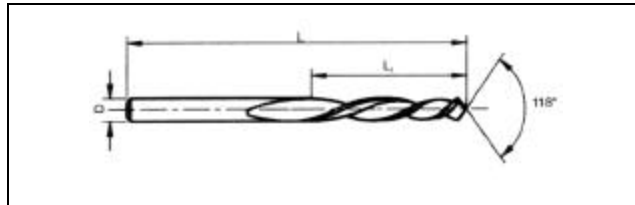

Other executions or dimensions and tolerances as well as TiN or TiAlN coating on request

D1 h6	L1	L	D1 h6	L1	L
1.00	12.00	38	4.00	32.00	75
1.20	14.00	38	4.10	33.00	75
1.50	15.00	40	4.20	34.00	75
1.80	16.00	46	4.30	35.00	80
1.90	16.00	46	4.40	36.00	80
2.00	16.00	49	4.50	36.00	80
2.10	17.00	49	4.60	37.00	80
2.20	18.00	50	4.70	38.00	80
2.30	19.00	50	4.80	39.00	86
2.40	20.00	50	4.90	40.00	86
2.50	20.00	50	5.00	40.00	86
2.60	21.00	57	5.10	41.00	86
2.70	22.00	61	5.20	42.00	86
2.80	23.00	61	5.30	43.00	86
2.90	24.00	61	5.40	44.00	93
3.00	24.00	61	5.50	44.00	93
3.10	25.00	65	5.60	45.00	93
3.20	26.00	65	5.70	46.00	93
3.30	27.00	65	5.80	47.00	93
3.40	28.00	70	5.90	48.00	96
3.50	28.00	70	6.00	48.00	96
3.60	29.00	70	6.50	52.00	101
3.70	30.00	70	7.00	56.00	109
3.80	31.00	75	7.50	60.00	109
3.90	32.00	75	8.00	60.00	117



Twist Drills

Type 1130 R

R = right hand cut

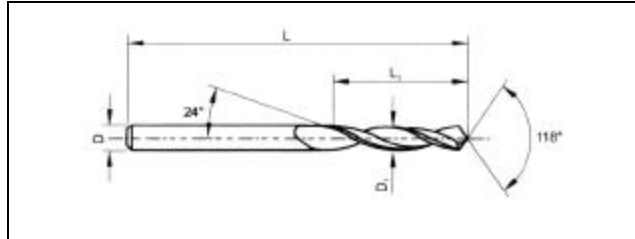

Other executions or dimensions and tolerances as well as TiN or TiAlN coating on request

D1 h6	L1	L	D1 h6	L1	L
0.30	5.00	30	1.80	9.00	38
0.35	5.00	30	1.85	9.00	38
0.40	6.00	30	1.90	9.00	38
0.45	6.00	30	1.95	9.00	38
0.50	6.00	30	2.00	9.00	38
0.55	6.00	30	2.05	9.00	38
0.60	6.00	30	2.10	9.00	38
0.65	6.00	30	2.15	10.00	40
0.70	6.00	30	2.20	10.00	40
0.75	6.00	30	2.25	10.00	40
0.80	7.00	30	2.30	10.00	40
0.85	7.00	30	2.35	10.00	40
0.90	7.00	30	2.40	11.00	43
0.95	7.00	30	2.45	11.00	43
1.00	7.00	30	2.50	11.00	43
1.05	8.00	30	2.55	11.00	43
1.10	8.00	30	2.60	11.00	43
1.15	8.00	30	2.65	11.00	43
1.20	8.00	30	2.70	12.00	46
1.25	8.00	30	2.75	12.00	46
1.30	8.00	30	2.80	12.00	46
1.35	8.00	30	2.90	12.00	46
1.40	8.00	30	2.95	12.00	46
1.45	8.00	30	3.00	12.00	46
1.50	8.00	30	3.05	14.00	49
1.55	9.00	38	3.10	14.00	49
1.60	9.00	38	3.15	14.00	49
1.65	9.00	38	3.20	14.00	49
1.70	9.00	38	3.25	14.00	49
1.75	9.00	38	3.30	14.00	49



Twist Drills

Type 1130 R

R = right hand cut

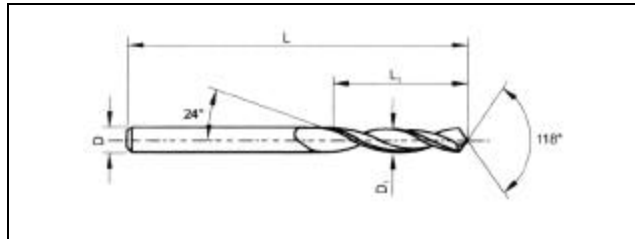

Other executions or dimensions and tolerances as well as TiN or TiAlN coating on request

Continued

D1 h6	L1	L	D1 h6	L1	L
3.35	14	49	4.80	20	62
3.40	15	52	4.85	20	62
3.45	15	52	4.90	20	62
3.50	15	52	4.95	20	62
3.55	15	52	5.00	20	62
3.60	15	52	* 5.10 - 5.30	20	62
3.65	15	52	5.40	21	66
3.70	15	52	5.50	21	66
3.75	15	52	5.60	21	66
3.80	17	55	* 5.70 - 6.00	21	66
3.85	17	55	* 6.10 - 6.50	23	70
3.90	17	55	* 6.60 - 6.70	23	70
3.95	17	55	* 6.80 - 7.00	25	74
4.00	17	55	7.50	25	74
4.05	17	55	8.00	27	79
4.10	17	55	8.50	27	79
4.15	17	55	9.00	29	84
4.20	17	55	9.50	29	84
4.25	17	55	10.00	31	89
4.30	18	58	10.20	31	89
4.35	18	58	10.50	31	89
4.40	18	58	11.00	33	95
4.45	18	58	11.50	33	95
4.50	18	58	12.00	35	102
4.55	18	58	12.50	35	102
4.60	18	58	13.00	35	102
4.65	18	58	13.50	37	107
4.70	18	58	14.00	37	107
4.75	20	58			

* available per 0.10mm



Rene Swiss Corp.

Twist Drills

Type 1130 L

L = left hand cut

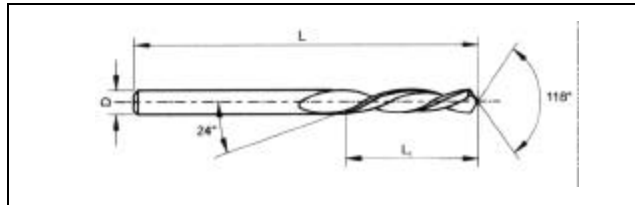

Other executions or dimensions and tolerances as well as TiN or TiAlN coating on request

D1 h6	L1	L	D1 h6	L1	L
0.30	5.00	30	4.00	22.00	50
0.35	5.00	30	4.05 - 4.25	22.00	50
0.40 - 0.45	6.00	30	4.30 - 4.50	24.00	50
0.50 - 0.55	6.00	30	4.55 - 4.75	24.00	50
0.60 - 0.65	6.00	30	4.80 - 4.95	25.00	50
0.70 - 0.75	6.00	30	5.00	25.00	50
0.80	8.00	30	5.10 - 5.50	25.00	50
0.85	8.00	30	5.60 - 5.90	25.00	50
0.90	8.00	30	6.00	28.00	66
0.95	8.00	30	6.10 - 6.50	31.00	70
1.00	8.00	30	6.60 - 6.70	31.00	70
1.05 - 1.50	10.00	30	6.80 - 6.90	34.00	74
1.55 - 1.75	16.00	38	7.00	34.00	74
1.80	16.00	38	7.50	34.00	74
1.85 - 1.95	16.00	38	8.00	37.00	79
2.00	16.00	38			
2.05 - 2.10	16.00	38			
2.15 - 2.30	16.00	40			
2.35	16.00	40			
2.40 - 2.50	16.00	43			
2.55 - 2.65	16.00	43			
2.70	16.00	46			
2.75 - 2.95	16.00	46			
3.00	16.00	46			
3.05 - 3.35	18.00	49			
3.40 - 3.50	20.00	50			
3.55 - 3.75	20.00	50			
3.80 - 3.95	22.00	50			

Available per 0.05mm up to Ø 5.00mm
then per 0.10mm up to Ø 7.00mm



Twist Drills Reinforced Shank

Type 1131 R

R = right hand cut

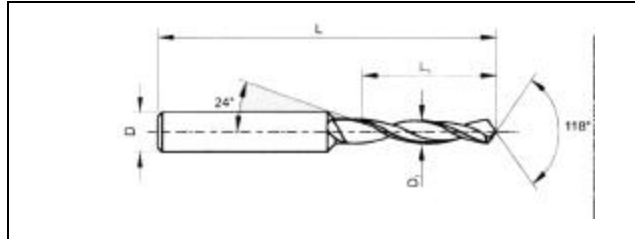

Other executions
or dimensions and
tolerances on
request

D1 0/-0.004	L1	D h6	L	D1 0/-0.004	L1	D h6	L
0.10	0.70	1.00	30	0.80	6.30	1.50	30
0.11 - 0.14	0.70	1.00	30	0.81 - 0.84	6.30	1.50	30
0.15	1.00	1.00	30	0.85	6.30	1.50	30
0.16 - 0.19	1.00	1.00	30	0.86 - 0.89	7.10	1.50	30
0.20	1.00	1.00	30	0.90	7.10	1.50	30
0.21 - 0.24	1.00	1.00	30	0.91 - 0.94	7.10	1.50	30
0.25	1.00	1.00	30	0.95	7.10	1.50	30
0.26 - 0.29	1.00	1.00	30	0.96 - 0.99	8.00	1.50	30
0.30	1.50	1.00	30	1.00	9.00	1.50	30
0.31 - 0.34	1.50	1.00	30	1.01 - 1.04	9.00	1.50	30
0.35	1.50	1.00	30	1.05	9.00	1.50	30
0.36 - 0.39	1.50	1.00	30	1.06 - 1.09	9.00	1.50	30
0.40	2.00	1.00	30	1.10	9.00	1.50	30
0.41 - 0.44	2.00	1.00	30	1.11 - 1.14	9.00	1.50	30
0.45	3.60	1.00	30	1.15	9.00	1.50	30
0.46 - 0.48	3.60	1.00	30	1.16 - 1.19	8.00	1.50	30
0.49	4.00	1.00	30	1.20	10.00	1.50	30
0.50	4.00	1.00	30	1.21 - 1.24	10.00	1.50	30
0.51 - 0.53	4.00	1.00	30	1.25	10.00	1.50	30
0.54	4.50	1.00	30	1.26 - 1.29	10.00	1.50	30
0.55	4.50	1.00	30	1.30	10.00	1.50	30
0.56 - 059	4.50	1.00	30	1.31 - 1.32	10.00	1.50	30
0.60	4.50	1.00	30	1.33 - 1.34	11.20	1.50	30
0.61 - 0.64	5.00	1.00	30	1.35	11.20	1.50	30
0.65	5.00	1.00	30	1.36 - 1.39	11.20	1.50	30
0.66 - 0.69	5.00	1.00	30	1.40	11.20	1.50	30
0.70	5.60	1.00	30	1.41 - 1.44	11.20	1.50	30
0.71 - 0.74	5.60	1.00	30	1.45	11.20	1.50	30
0.75	5.60	1.00	30	1.46 - 1.49	11.20	1.50	30
0.76 - 0.79	6.30	1.00	30				

Available per 0.01mm



Rene Swiss Corp.

Twist Drills Reinforced Shank

Type 1131 R

R = right hand cut

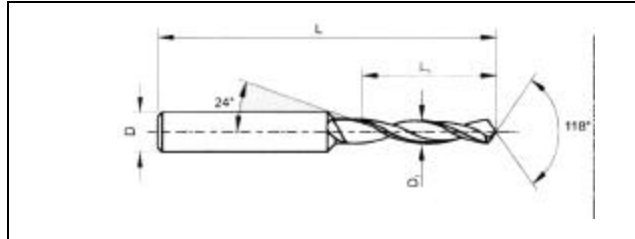

Other executions
or dimensions and
tolerances on
request

Continued

D1 0/-0.004	L1	D h6	L	D1 0/-0.004	L1	D h6	L
1.50	11.20	2.00	38	2.00	12.00	2.50	43
1.51 - 1.54	12.00	2.00	38	2.01	12.00	2.50	43
1.55	12.00	2.00	38	2.05	12.00	2.50	43
1.56 - 1.59	12.00	2.00	38	2.10	12.00	2.50	43
1.60	12.00	2.00	38	2.15	12.00	2.50	43
1.61 - 1.64	12.00	2.00	38	2.20	12.00	2.50	43
1.65	12.00	2.00	38	2.25	12.00	2.50	43
1.66 - 1.69	12.00	2.00	38	2.30	12.00	2.50	43
1.70	12.00	2.00	38	2.35	12.00	2.50	43
1.71 - 1.72	12.00	2.00	38	2.40	12.00	2.50	43
1.73	12.00	2.00	38	2.45	12.00	2.50	43
1.74	12.00	2.00	38				
1.75	12.00	2.00	38				
1.76 - 1.79	12.00	2.00	38				
1.80	12.00	2.00	38				
1.81 - 1.84	12.00	2.00	38				
1.85	12.00	2.00	38				
1.86 - 1.89	12.00	2.00	38				
1.90	12.00	2.00	38				
1.91 - 1.94	12.00	2.00	38				
1.95	12.00	2.00	38				
1.96 - 1.99	12.00	2.00	38				

Available per 0.01mm



Twist Drills Reinforced Shank

Type 1131 L

L = left hand cut

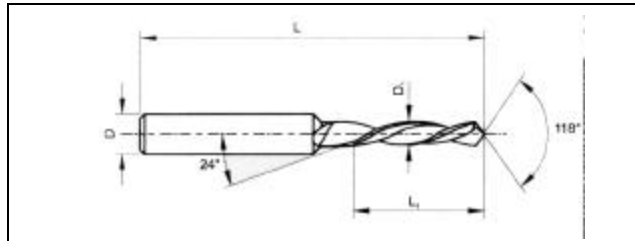

Other executions
or dimensions and
tolerances on
request

D1 0/-0.004	L1	D h6	L	D1 0/-0.004	L1	D h6	L
0.10 - 0.14	0.70	1.00	30	0.81 - 0.84	6.30	1.50	30
0.15	1.00	1.00	30	0.85	6.30	1.50	30
0.16 - 0.19	1.00	1.00	30	0.86 - 0.89	7.10	1.50	30
0.20	1.00	1.00	30	0.90	7.10	1.50	30
0.21 - 0.24	1.00	1.00	30	0.91 - 0.94	7.10	1.50	30
0.25	1.00	1.00	30	0.95	7.10	1.50	30
0.26 - 0.29	1.00	1.00	30	0.96 - 0.99	8.00	1.50	30
0.30	1.50	1.00	30	1.00	9.00	1.50	30
0.31 - 0.34	1.50	1.00	30	1.01 - 1.04	9.00	1.50	30
0.35	1.50	1.00	30	1.05	9.00	1.50	30
0.36 - 0.39	1.50	1.00	30	1.06 - 1.09	9.00	1.50	30
0.40	2.00	1.00	30	1.10	9.00	1.50	30
0.41 - 0.44	2.00	1.00	30	1.11 - 1.14	9.00	1.50	30
0.45	3.60	1.00	30	1.15	9.00	1.50	30
0.46 - 0.48	3.60	1.00	30	1.16 - 1.18	9.00	1.50	30
0.49	4.00	1.00	30	1.19	10.00	1.50	30
0.50	4.00	1.00	30	1.20	10.00	1.50	30
0.51 - 0.53	4.00	1.00	30	1.21 - 1.24	10.00	1.50	30
0.54	4.50	1.00	30	1.25	10.00	1.50	30
0.55	4.50	1.00	30	1.26 - 1.29	10.00	1.50	30
0.56 - 0.59	4.50	1.00	30	1.30	10.00	1.50	30
0.60	4.50	1.00	30	1.31 - 1.32	10.00	1.50	30
0.61 - 0.64	5.00	1.00	30	1.33 - 1.34	11.20	1.50	30
0.65	5.00	1.00	30	1.35	11.20	1.50	30
0.66 - 0.69	5.00	1.00	30	1.36 - 1.39	11.20	1.50	30
0.70	5.60	1.00	30	1.40	11.20	1.50	30
0.71 - 0.74	5.60	1.00	30	1.41 - 1.44	11.20	1.50	30
0.75	5.60	1.00	30	1.45	11.20	1.50	30
0.76 - 0.79	6.30	1.00	30	1.46 - 1.49	11.20	1.50	30
0.80	6.30	1.50	30				

Available per 0.01mm



Twist Drills Reinforced Shank

Type 1131 L

L = left hand

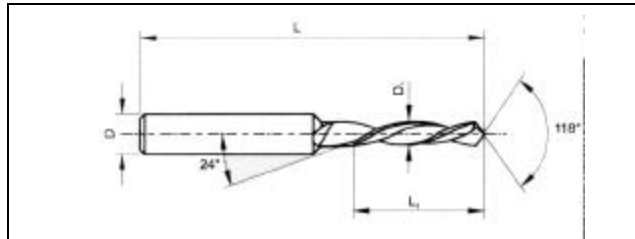

Other executions
or dimensions and
tolerances on
request

Continued

D1 0/-0.004	L1	D h6	L
1.50	11.20	2.00	38
1.51 - 1.54	12.00	2.00	38
1.55	12.00	2.00	38
1.56 - 1.59	12.00	2.00	38
1.60	12.00	2.00	38
1.61 - 1.64	12.00	2.00	38
1.65	12.00	2.00	38
1.66 - 1.69	12.00	2.00	38
1.70	12.00	2.00	38
1.71 - 1.74	12.00	2.00	38
1.75	12.00	2.00	38
1.77	12.00	2.00	38
1.80	12.00	2.00	38
1.82	12.00	2.00	38
1.85	12.00	2.00	38
1.87	12.00	2.00	38
1.90	12.00	2.00	38
1.91 - 1.94	12.00	2.00	38
1.95	12.00	2.00	38
2.00	12.00	2.00	43
2.01 - 2.02	12.00	2.00	43
2.10	12.00	2.00	43
2.12	12.00	2.00	43
2.15	12.00	2.00	43
2.45	12.00	2.00	43
2.60	12.00	2.00	46

Available per 0.01mm



Twist Drills

Type 1132 R

R = right hand cut

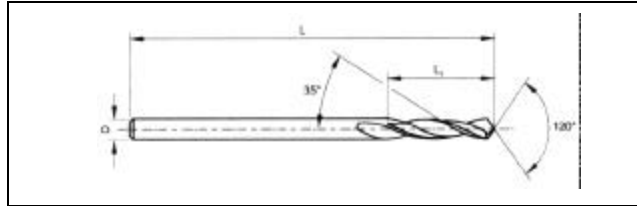

Other executions, dimensions, left hand cut and tolerances as well as TiN or TiAlN coating on request

D1 h6	L1	L
0.40	6.00	30
0.45	6.00	30
0.50	6.00	30
0.55	6.00	30
0.60	6.00	30
0.65	6.00	30
0.70	6.00	30
0.75	6.00	30
0.80	7.00	30
0.85	7.00	30
0.90	7.00	30
0.95	7.00	30
1.00	8.00	30
1.05	8.00	30
1.10	8.00	30
1.15	8.00	30
1.20	8.00	30
1.25	8.00	30
1.30	8.00	30
1.35	8.00	30
1.40	8.00	30
1.45	8.00	30
1.50	9.00	30
1.55	9.00	38
1.60	9.00	38
1.65	9.00	38
1.70	9.00	38
1.75	9.00	38
1.80	9.00	38
1.85	9.00	38
1.90	9.00	38
1.95	9.00	38
2.00	9.00	38



Twist Drills Long Execution

Type 1133 R

R = right hand cut

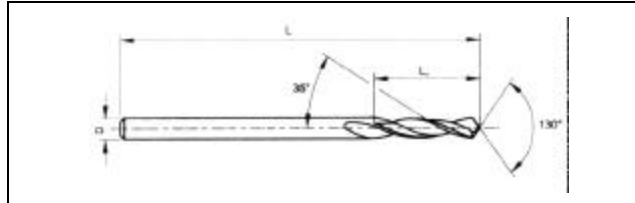

Other executions or dimensions and tolerances as well as TiN or TiAlN coating on request

D1 h6	L1	L	D1 h6	L1	L
0.50	9.00	38	2.00	16.00	38
0.55	9.00	38	2.10	16.00	38
0.60	13.00	38	2.20	16.00	40
0.65	13.00	38	2.30	16.00	40
0.70	13.00	38	2.40	16.00	43
0.75	13.00	38	2.40	16.00	43
0.80	13.00	38	2.60	16.00	43
0.85	13.00	38	3.00	16.00	46
0.90	16.00	38	3.30	18.00	49
0.95	16.00	38	3.50	20.00	50
1.00	16.00	38	4.00	22.00	55
1.05	16.00	38	4.20	22.00	55
1.10	16.00	38	4.50	24.00	58
1.15	16.00	38	5.00	26.00	62
1.20	16.00	38	5.50	28.00	66
1.25	16.00	38	6.00	28.00	66
1.30	16.00	38			
1.35	16.00	38			
1.40	16.00	38			
1.45	16.00	38			
1.50	16.00	38			
1.55	16.00	38			
1.60	16.00	38			
1.65	16.00	38			
1.70	16.00	38			
1.75	16.00	38			
1.80	16.00	38			
1.85	16.00	38			
1.90	16.00	38			
1.95	16.00	38			



Twist Drills Reinforced Shank

Type 1134 R

R = right hand cut

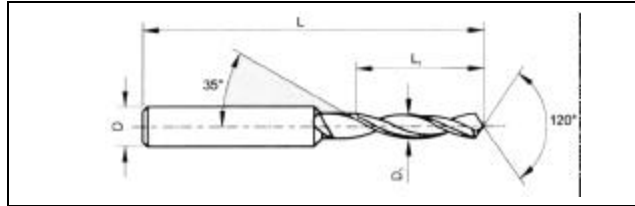

Other executions
or dimensions and
tolerances on
request

D1 0/-0.004	L1	D h6	L
0.50	4.00	1.00	30
0.55	4.50	1.00	30
0.60	4.50	1.00	30
0.65	5.00	1.00	30
0.70	5.60	1.00	30
0.75	5.60	1.00	30
0.80	6.30	1.50	30
0.85	6.30	1.50	30
0.90	7.10	1.50	30
0.95	7.10	1.50	30
1.00	9.00	1.50	30
1.05	9.00	1.50	30
1.10	9.00	1.50	30
1.15	9.00	1.50	30
1.20	10.00	1.50	30
1.25	10.00	1.50	30
1.30	10.00	1.50	30
1.35	11.20	1.50	30
1.40	11.20	1.50	30
1.45	11.20	1.50	30
1.50	11.20	2.00	38
1.90	12.00	2.00	38



Twist Drills For Tough Materials

Type 1149 R & L

R = right hand cut
L = left hand cut

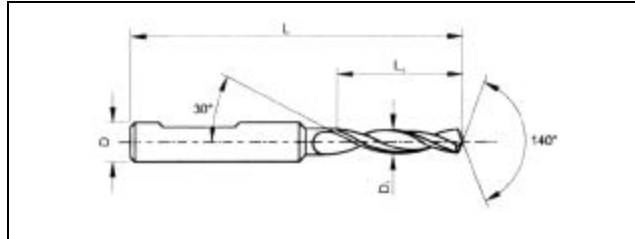

Other executions
or dimensions and
tolerances on
request

D1 h6	L1	D h6	L
0.50 - 0.53	4.00	1.00	30
0.54 - 0.60	4.50	1.00	30
0.61 - 0.69	5.00	1.00	30
0.70 - 0.75	5.60	1.00	30
0.76 - 0.79	6.30	1.00	30
0.80 - 0.85	6.30	1.50	30
0.86 - 0.95	7.10	1.50	30
0.96 - 0.99	8.00	1.50	30
1.00 - 1.19	9.00	1.50	30
1.20 - 1.32	9.00	1.50	30
1.33 - 1.49	9.00	1.50	30
1.50	9.00	2.00	38
1.51 - 1.99	9.00	2.00	38

When ordering, please specify
the material to be machined,
D1, L1, D, L and the direction
of cut (R or L)



Twist Drills For Tough Materials

Type 1149 R

R = right hand cut

Whistle notch from shank \varnothing 6mm

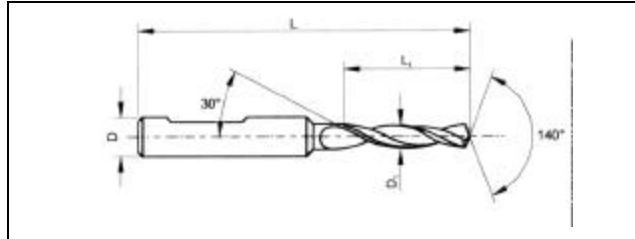

Other executions or dimensions and tolerances on request

D1 h6	L1	D h6	L	D1 h6	L1	D h6	L
2.00	9.00	3.00	50	5.00	20.00	6.00	66
2.10	9.00	3.00	50	5.20	20.00	6.00	66
2.20	9.00	3.00	50	5.30	20.00	6.00	66
2.30	9.00	3.00	50	5.50	20.00	6.00	66
2.40	9.00	3.00	50	5.80	22.00	6.00	66
2.50	9.00	3.00	50	6.00	22.00	6.00	66
2.60	11.00	4.00	50	6.30	24.00	8.00	79
2.70	11.00	4.00	50	6.50	24.00	8.00	79
2.80	11.00	4.00	50	6.60	24.00	8.00	79
2.90	11.00	4.00	50	6.80	24.00	8.00	79
3.00	14.00	6.00	62	7.00	25.00	8.00	79
3.10	14.00	6.00	62	7.50	29.00	8.00	79
3.20	14.00	6.00	62	7.80	29.00	8.00	79
3.30	14.00	6.00	62	8.00	29.00	8.00	79
3.40	14.00	6.00	62	8.50	35.00	10.00	89
3.50	14.00	6.00	62	9.00	35.00	10.00	89
3.60	14.00	6.00	62	9.50	35.00	10.00	89
3.70	14.00	6.00	62	9.80	35.00	10.00	89
3.80	17.00	6.00	66	10.00	35.00	10.00	89
3.90	17.00	6.00	66	10.20	40.00	12.00	102
4.00	17.00	6.00	66	10.50	40.00	12.00	102
4.10	17.00	6.00	66	11.00	40.00	12.00	102
4.20	17.00	6.00	66	11.50	41.00	12.00	102
4.30	17.00	6.00	66	12.00	42.00	12.00	102
4.40	17.00	6.00	66	13.00	46.00	14.00	107
4.50	17.00	6.00	66	14.00	49.00	14.00	107
4.60	17.00	6.00	66				
4.70	17.00	6.00	66				
4.80	20.00	6.00	66				
4.90	20.00	6.00	66				



Rene Swiss Corporation
14 Townline Road
Wolcott, CT 06716

Tel. 203.879.4822
Fax. 203.879.0732

www.reneswiss.com
rachel@reneswiss.com